

Product Information

COLD WIRE FEEDERS

- Microprocessor Control
- Four-Drive Rolls
- Optional Pulsed Feed
- Wire Guide Positioner
- Standard or Precision Drive
- Wide Range of Accessories

Introduction

Jetline cold wire feeders are primarily used for gas tungsten arc welding (TIG) and plasma arc welding (PAW). They can also be used in other applications where a controlled feed of wire is required such as a brazing operation.

Cold wire feeding is used in the welding process for four purposes:

- 1 To add "fill" to a weld joint. The wire is used to fill a chamfered weld preparation or to add reinforcement for a butt weld.
- 2 To enhance or preserve the metallurgical integrity of the weld metal by selecting the wire type to add the required elements to the weld or to replace those which are lost as a result of the welding operation.
- 3 To control the weld pool by the chilling action of the wire, especially in out-of-position weld applications. The chilling effect reduces the weld pool size for easier control.
- 4 To provide the fill for an overlay or cladding operation. The wire can be selected to provide the desired properties for the application.

All Jetline wire feeders are suitable for any of the above applications. The standard CWF-50 is competitively priced and provides smooth, consistent wire feed for almost all types of welding wire, both hard and soft. The CWF-20C precision model is available for demanding applications where wire feed speed accuracy is critical.



CWF-50 Cold Wire Feeder
Typical mounting on a longitudinal seamer

Description

A Jetline cold wire feeder consists of the following elements:

- Wire Feedhead and spool holder
- 9629 Microprocessor Controller
- WGP-1 Wire Guide Positioner Assembly

Optional items are available including:

- Pulsed Wire Feed
- Wire Feed Accessory Kits
- Protective Spool Cover
- Motorized Wire Guide Positioner
- Compact Wire Guide Positioner

Speed Accuracy

The CWF-50 uses a wire drive mechanism providing a speed holding accuracy of $\pm 1\%$ of the rated speed.

The CWF-20C is a high accuracy cold wire feeder which uses a precision motor with integrated tach-generator and a precision drive control to provide speed holding accuracies of $\pm 0.1\%$ of the rated speed.

Both models come with integrated tach generators to allow the feeder to be operated under closed-loop control for greater speed holding accuracy.

COLD WIRE FEEDERS

Wire Feedhead and Spoolholder



The wire feedhead and the spoolholder are mounted on a common base to permit a smooth transfer of the wire from the spool, through the feed rolls, to the wire feed conduit. The feedhead should be mounted as close as possible to the welding torch. Brackets are available for this purpose, if required. The unit incorporates a spoolholder for standard spools with a 2" (50 mm) hole. A clear plastic cover is optionally available to protect the wire spool from the dust in the workshop atmosphere.

The four-roll wire feed mechanism is gear driven, providing a smooth wire feed with no possibility of slippage.

Microprocessor Controller



All Jetline wire feeders are furnished with the 9629 microprocessor control. This control is similar to those provided with Jetline travel devices and provides full control of all the aspects of the wire feeder.

The 9629 control is user-friendly and uses simple menu commands to guide the operator through the setting up and operation of the unit. The 9629 control has three modes:

- **Operator Mode**
- **Set-up Mode**
- **Calibration Mode**

Operator Mode

This is the mode which is automatically selected when the unit is switched on. It is designed to permit the operator to access the functions required for the successful operation of the wire feeder. These functions include:

- **Setting of wire feed speed**
- **Setting of wire start delay time**
- **Setting of wire stop delay time**
- **Wire retract time**

Set-up Mode

In this mode of operation, it is possible to set up various features of the control, including:

- **Forward jog speed**
- **Reverse jog speed**
- **Rapid speed**
- **Retract speed**

If the wire feeder is supplied with the optional pulsed wire capability, the following features may also be set in the set-up mode:

- **Pulsed wire feed condition**
- **Low speed**
- **Wire pulse mode** for high and low pulse time

Calibration Mode

A unique feature of Jetline cold wire feeders is the ability to set up and maintain the calibration of the controls. This is vital for users requiring regular calibration checking of their equipment and for applications where the accuracy and consistency of the wire feeding is important for the maintenance of high quality welding procedures. In the calibration mode, it is possible to set the following features:

- **Closed loop mode**
- **Loop sensing**
- **Sensing delay time**
- **Display mode**
- **High limit**
- **High output**
- **High input**
- **Low limit**
- **Low output**
- **Low input**
- **Units of measurement**
- **Hour meter**

Accessory Kits for Mechanized Welding

A range of accessory kits, which include drive rolls, guides, wire feed conduit and wire guide tips, are available. Kits for the appropriate size wire are to be ordered along with the cold wire feed system. Available wire sizes are:

- .020" (0.5 mm) Hard Wire
- .030" (0.8 mm) Hard Wire
- .035" (0.9 mm) Hard & Soft Wire
- .045" (1.2 mm) Hard & Soft Wire
- .062" (1.6 mm) Hard & Soft Wire
- .093" (2.4 mm) Hard & Soft Wire

COLD WIRE FEEDERS

Wire Guide Positioner

The **WGP-1** wire guide positioner is supplied as standard with all Jetline cold wire feeders. The unit fits easily on almost any torch for gas tungsten or plasma arc welding and incorporates three axes of adjustment. The horizontal and vertical axes are manually adjustable while welding to optimize the wire entry position into the weld pool.



As an alternative to the standard WGP-1 positioner, two other types are available.

The **WGP-3** is a compact positioner using a curved wire guide tip and is offered as an option. For applications where space is constricted, the **WGP-3** curved wire guide positioner can be used. This fits on the torch and has the same type of adjustments as the standard WGP-1 wire guide positioner.



The **WGP-2ES** is a motorized version of the WGP-1. The two axes of adjustment are remotely adjusted using a joystick control. This positioner is suitable for use with Jetline video monitoring systems.



Optional Accessories

Model 607B Wire Spool Cover

This is a transparent cover designed to protect the wire from the dust and dirt of the workshop.

Pulsed Wire Feed

This feature provides the ability to pulse the wire feed and consists of optional firmware which can be used with standard or precision feeders.

Wire Straightener

This is a three roll straightener suitable for all wire diameters up to 1/16" (1.6 mm).

Associated Products

Jetline also produces the following wire feeders.

9500 Compatible Wire Feeder

This wire feeder is designed for use with Jetline's unique 9500, 4-channel microprocessor control. The 9629 control is replaced by an MCM-1 motor control module to interface with the 9500 control.



9500 System Control

HWP-50 Hot Wire Process

The hot wire process includes a special hot wire power supply which "preheats" the wire as it enters the weld pool to provide high deposition rates with enhanced weld pool quality. This process is suitable for the welding of heavy plate and pipe, as well as the deposition of welded coatings.

CWF-23D Dabber-type Wire Feeder

The "dabber-type" wire feeder is used for the precise, controlled buildup of worn "knife-edge" type joints or worn aero-engine parts. Jetline's system operates with the 9500 microprocessor controller or the Jetstar computer controller.

COLD WIRE FEEDERS

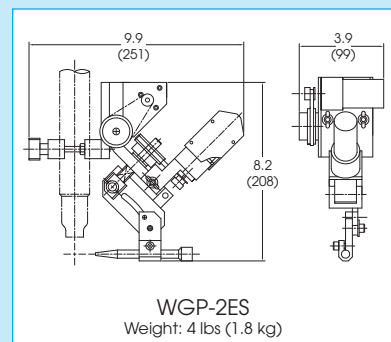
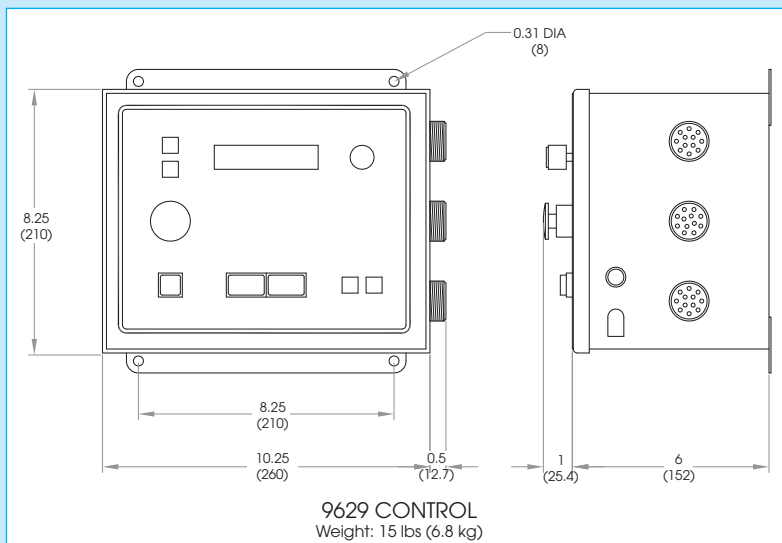
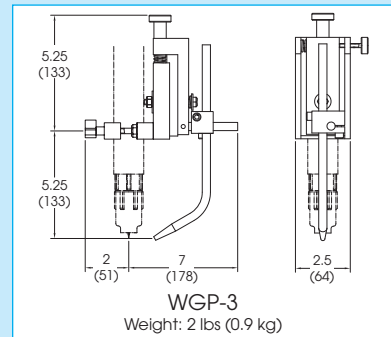
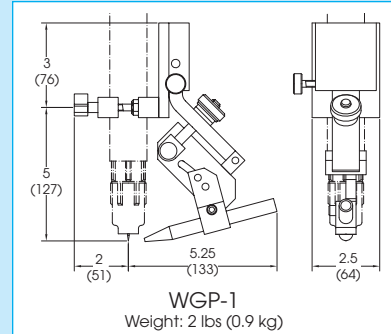
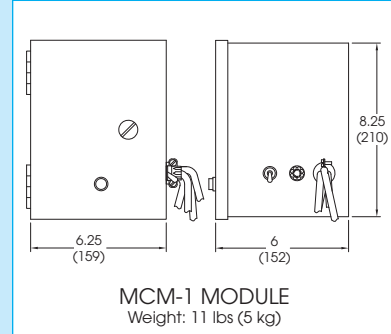
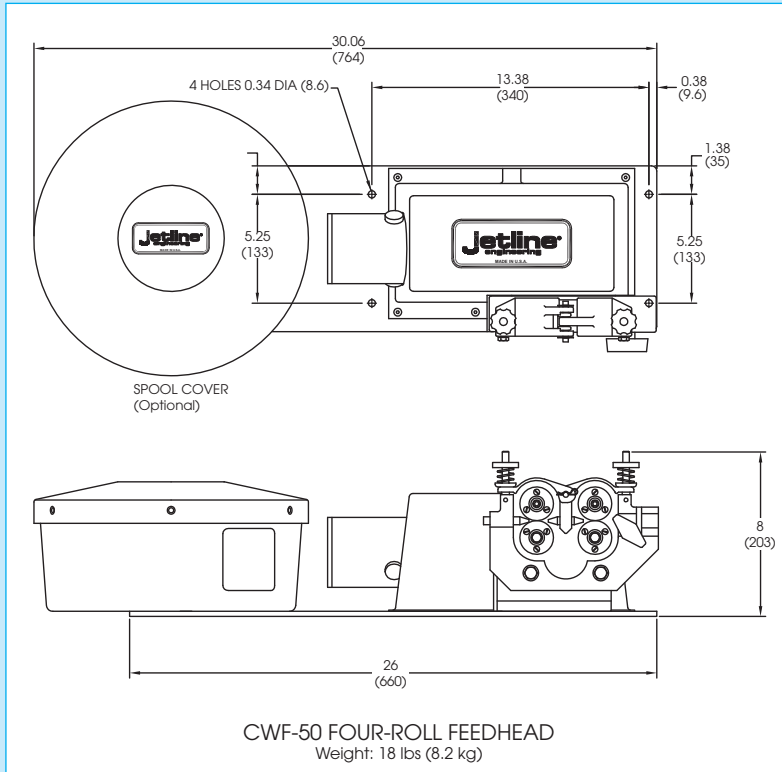

All dimensions are in inches (mm)

See Jetline price list for complete ordering information

Distributed by:



15 Goodyear St., Irvine, California 92618 USA
Tel: (949) 951-1515 • Fax: (949) 951-9237 • E-mail: sales@jetline.com

Web Page: www.jetline.com • www.cyclomatic.com