



MODEL NO:

WP-250

230V model available for export

FEATURES:

- 13-3/4" Diameter Table
- 0 to 5.5 RPM Rotation Speed
- Manual Tilt Adjustment
- 115V
- 0 to 90° Tilting Angle
- High Frequency Protected
- Standard w/Foot Control Switch
- Shipping Weight 113 lbs.

Designed for rotation of lighter work pieces. Will hold 440 lbs. in the horizontal position and 250 lbs. in the vertical position.
Note: C/G of load not to be more than 4" from the center of the turntable and 4" from the face of the turntable.

(Foot Control CFS-302)

FEATURES:

- Low Profile
- Self Centering
- Reversible Jaws
- Easy Mounting
- External & Internal Gripping
 - 0" - 8" on O.D.
 - 3" - 11" on I.D.
- Shipping Weight 20 lbs.

MODEL NO:

WPC-11

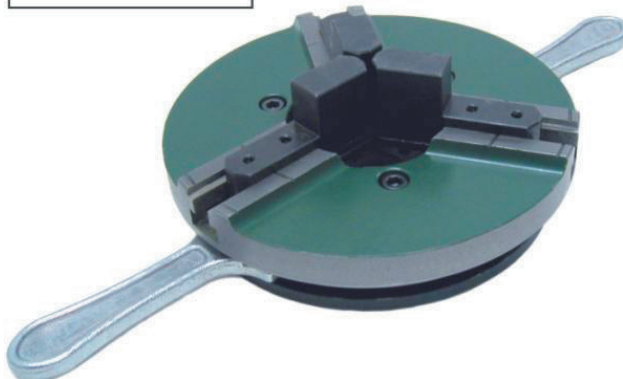

The above illustration shows the chuck mounted to the PROFAX Welding Positioner WP-250.

Positioner Dimensional Drawings

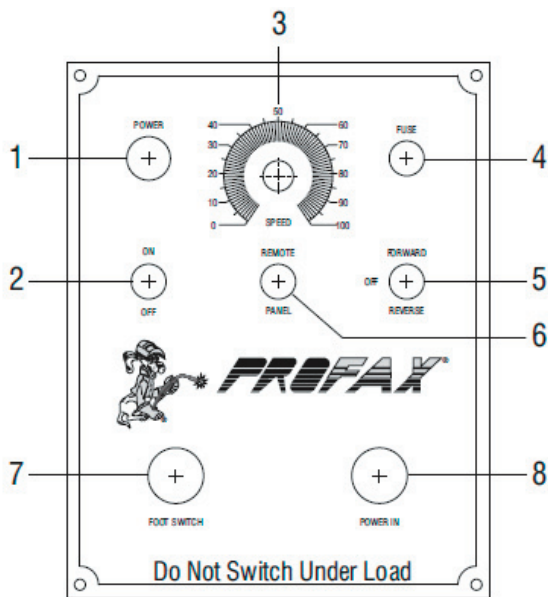
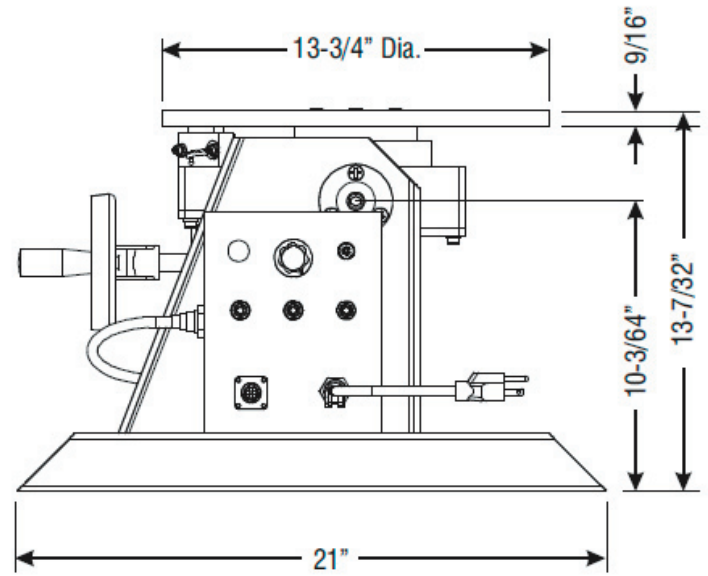
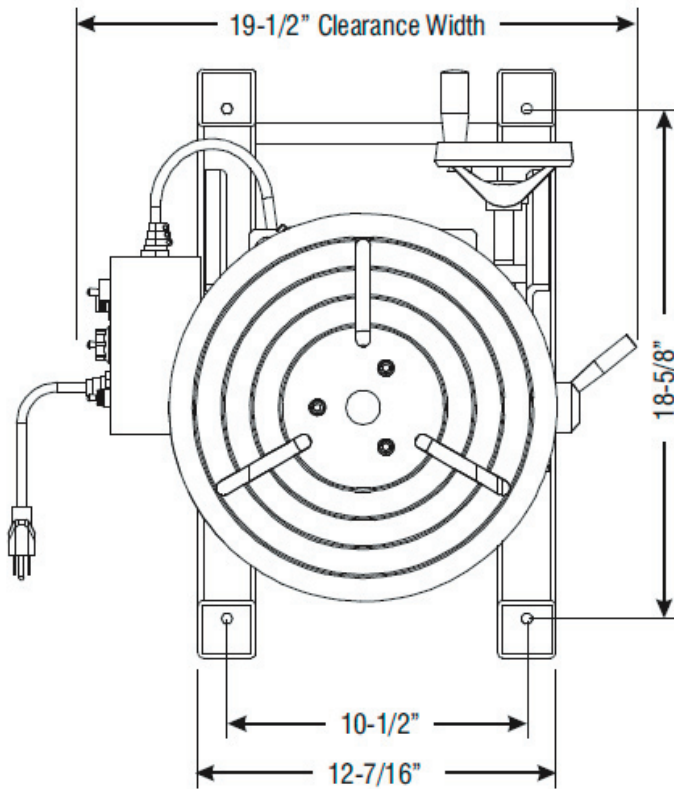

1. Pilot Light: Lights up red to indicate power on.
2. Power On-Off Switch
3. Speed Control: Provides control of table rotation speed from 0%(0 RPM) to 100%(5 RPM).
4. Fuse Holder: Fuse 5 amp
5. Forward/Off/Reverse Switch: Controls table rotation. Forward (clockwise rotation) and Reverse (counterclockwise rotation).
6. Remote/Panel Switch: Remote = Start and stop are remotely controlled. Panel = Start and stop are operated from the control box.
7. Remote Plug: Plug-in for the foot switch to start and stop of the turn table rotation.
8. Power in

PROFAX[®]

